

TYPICAL DOOR LOCATION DETAIL

** HORIZONTAL RUNNING CLEARANCES AS REQUIRED BY ASME A17.1, SECTION 5.3

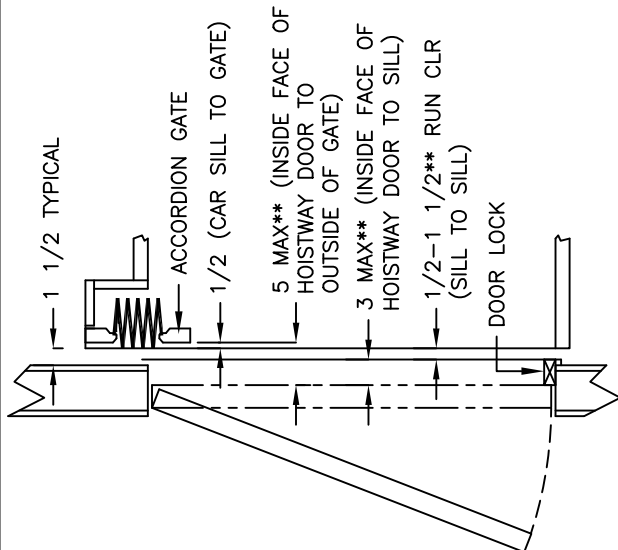

NOTES:

- 1) DIMENSIONS ARE FOR LEVEL 4,5, OR 6 CAB.
- 2) SHOW LOCATIONS OF COP, HANDRAIL & ACCESSORIES IF DIFFERENT THAN SHOWN.
- 3) *-DIMENSION IS FOR CENTERLINE OF STANDARD 36" DOOR. FOR OTHER SIZE, CONSULT FACTORY.
- 4) TYPICAL WOOD FRAME BACKING WITH (4)2x10'S, 25" O.C. REF. EL-2003B. FOR ANY OTHER APPLICATION CONSULT DEALER.
- 5) ALL DIMENSIONS IN INCHES.
- 6) COP=CAR OPERATING PANEL, PB=OPTIONAL RECESSED PHONE BOX, HC=HALL CALL (TYP ALL FLOORS)

90 DEGREE - 2 RH DOORS

**National
Wheel-O-Vator**

509 W. FRONT ST.
ROANOKE, ILLINOIS 61561
1-800-551-9095

DESTINY RESIDENTIAL ELEVATOR		DWG BY: KMG
SCALE: NONE	8/23/07	DWG #: EL-2037AG
JOB:		
DEALER:		