

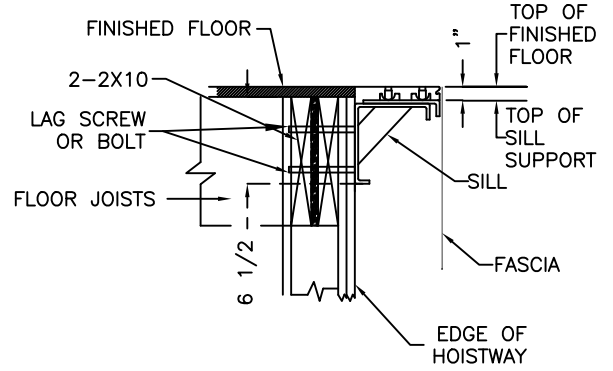

ENTRANCE ELEVATION  
TWO SPEED LEFT HAND DOOR & ENTRANCE  
(FRONT)

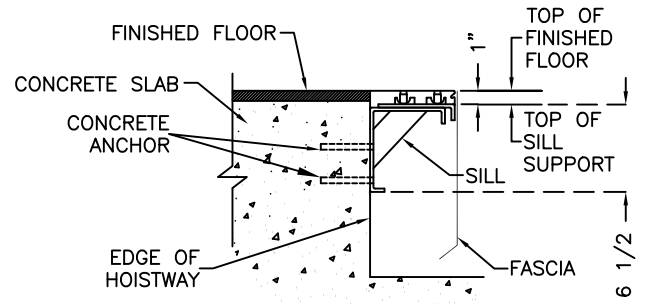
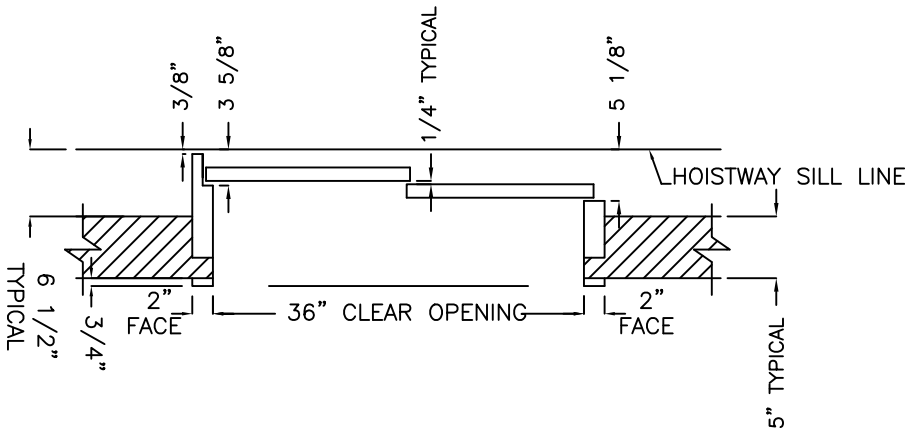

SILL SUPPORT DETAILS

- 1) HOISTWAY ENTRANCES ARE MANUFACTURED IN ACCORDANCE WITH 1 1/2 HR. FIRE RATED CONSTRUCTION.
- 2) HOISTWAY WALLS TO HAVE A FIRE ENDURANCE RATING NOT LESS THAN THAT REQUIRED BY RULE 2.1.1 OF ANSI A17.1 ELEVATOR SAFETY CODE.
- 3) FURNISHING, INSTALLING AND MAINTAINING THE REQUIRED FIRE RATING OF ELEVATOR HOISTWAY WALLS, INCLUDING THE PENETRATION OF FIRE WALL BY ELEVATOR FIXTURE BOXES, IS NOT THE RESPONSIBILITY OF THE ELEVATOR CONTRACTOR OR ELEVATOR ENTRANCE MANUFACTURER.
- \*4) HOISTWAY WALLS AT ENTRANCES ARE TO BE BUILT AFTER DOOR SILLS AND FRAMES ARE SET IN PLACE. IF THIS IS NOT FEASIBLE, LEAVE A 48"W X 92"H ROUGH OPENING.
- 5) FILLING AND GROUTING BY GENERAL CONTRACTOR.
- 6) DOOR WEIGHT IS 63# PER PANEL.

<b>NATIONAL WHEEL-O-VATOR</b>			
509 W. FRONT ST. ROANOKE, ILLINOIS 61561 800-551-9095			
36" ENTRANCE FRAME LEFT HAND			
EVOLUTION ELEVATOR EV-1018L			
SCALE:	DATE:	DRAWN BY:	DRAWING NUMBER:
NONE	11/8/07	MW	EV-1018L
DEALER:			
JOB:			