

PLAN VIEW

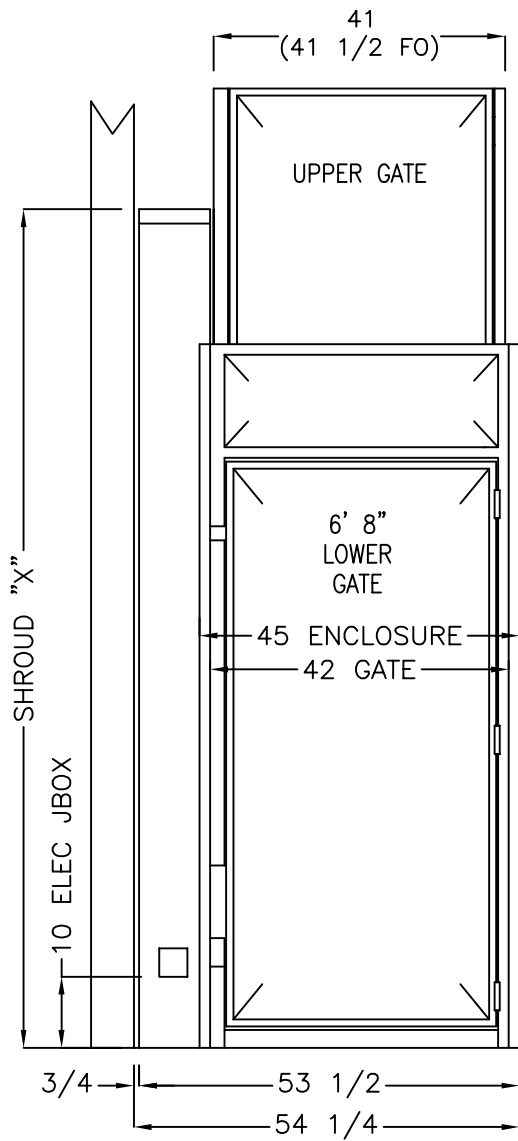

FRONT VIEW

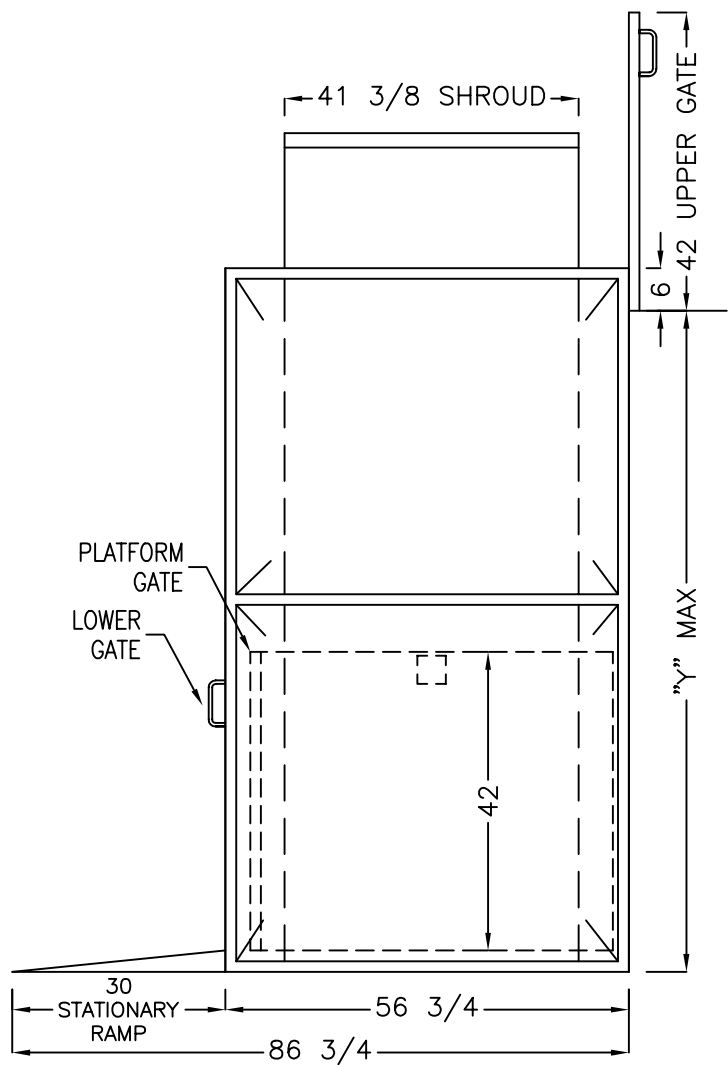

SIDE VIEW

MODEL	"X" IN.	"Y" IN.					
HCDE-96	123	99					
HCDE-108	135	111					
HCDE-120	147	123					
HCDE-144	171	147					

**DIMENSIONS SUBJECT TO CHANGE WITHOUT NOTIFICATION.**

**NATIONAL WHEEL-O-VATOR**  
509 W. FRONT ST. ROANOKE, ILLINOIS 61561  
1-800-551-9095

JANUARY 2003

MODEL: HCDE SHROUD LEFT DRAWING NUMBER: HCC-2010

ALL DIMENSIONS SUBJECT TO STANDARD INDUSTRY TOLERANCES UNLESS OTHERWISE SPECIFIED.